

For increased power into hazardous areas

MTL 700P SERIES

Shunt-diode safety barriers



STOCK

Intrinsically safe products - FAST

Selected items within this Series are available in the UK through MTL's new express service



- ◆ **More power than standard barriers**
- ◆ **Higher-power barriers for group IIC gases**
- ◆ **BASEEFA, FM, CSA and SA approved**
- ◆ **Complementary to MTL700 Series**

MTL700P Series shunt-diode safety barriers have been developed for the same applications as similarly numbered MTL700 Series barriers, but are designed to deliver more power into hazardous areas. Two types of MTL700P Series barrier exist. The first type (two barriers) is designed specifically for group IIB gases, which permit considerably more power, while the other (seven barriers) takes advantage of a change in the BSI's interpretation of the European standard EN 50 020 (bringing it into line with that of other European certifying authorities and also corresponding with the requirements of North American standards). This interpretation removes the requirement to increase the value of the safety voltage by 10% before determining the maximum allowed current from the published ignition curves. This allows the end-to-end resistance of the barrier to be reduced, with the result that it is possible to supply more power into a IIC gas group area.

Because of the higher power levels available, it is important when considering the use of MTL700P barriers to check the compatibility of the electrical safety parameters of the field equipment (such as transmitters and solenoid valves) with those of the barriers to make sure the combination is safe.

In addition, with the barriers designed for IIB gas group applications, the overall gas classification of the system also needs checking. The example below shows an MTL707P IIB barrier used with IIC field equipment in a IIB gas group area. This gives an overall system classification of group IIB despite the group IIC certification of the transmitter.

In common with the MTL700 Series, the higher-power barriers are 1- or 2- channel devices which pass an electrical signal in either direction without shunting it, but which limit the transfer of energy to the hazardous area to a level that cannot ignite explosive atmospheres. The MTL700P barriers, in the same way as the MTL700 Series, also retain protection against short circuits in the hazardous area, and feature cable parameters which do not introduce loop design problems for the majority of applications.

The mechanical design of the higher-power barriers is the same as for the MTL700 Series, so barriers from both Series can be mounted, earthed and used together with the same accessories. See page 2-7 for explanations of the terminology used, common specifications and mechanical details, and pages 2-20 to 2-23 for mounting details, enclosures and accessories.

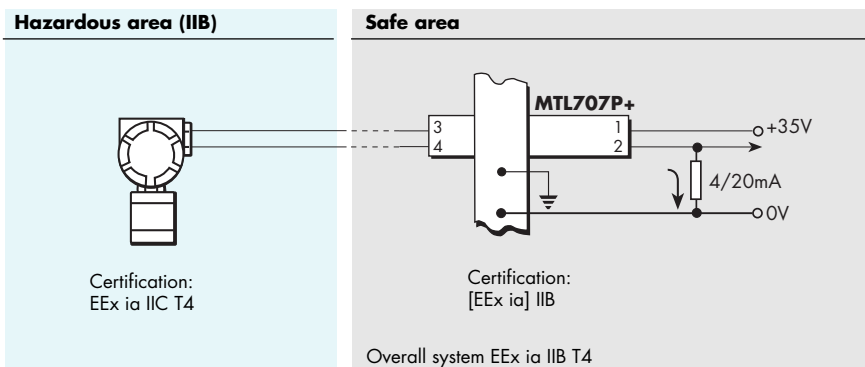

MTL700P SERIES HIGHER-POWER BARRIERS



(For notes 1 to 6, see 'Terminology' on page 2-7)

| Model No. MTL | Gas group | 1 Safety description | | | 2 Polarities available | | | Application | Basic circuit | | 3 Max. end-to-end resistance Ω | 4 V_{wkg} at $10\mu A$ V | 5 V_{max} V | 6 Fuse rating mA |
|---------------|-----------|----------------------|--------------|------------|------------------------|---|----|---|---------------|------------------------------|---------------------------------------|----------------------------|---------------|------------------|
| | | V | Ω | mA | + | - | ac | | hazardous | safe | | | | |
| 707P | IIB | 28 15 | 164 diode | 171 - | √ | | | Transmitters, controller outputs | | See additional specification | | 35 | 50 | |
| 710P | IIC | 10 | 33 | 300 | √ | √ | | 8V dc systems | | 42 | 8.0 | 9.2 | 200 | |
| 715P | IIC | 15 | 50 | 291 | √ | | | 12V dc systems | | 60 | 12.5 | 13.8 | 200 | |
| 722P | IIC | 22 | 101 | 213 | √ | | | 18V dc systems | | 121 | 18.5 | 20.0 | 100 | |
| 728P | IIC | 28 | 234 | 119 | √ | | | Controller outputs, solenoid valves | | 253 | 24.5 | 26.0 | 100 | |
| 729P | IIB | 28 | 164 | 171 | √ | | | Controller outputs, solenoid valves | | 184 | 24.5 | 26.0 | 100 | |
| 761P | IIC | 9 9 | 350 350 | 25 25 | | √ | | Strain-gauge bridges | | 384 384 | 7.0 7.0 | 8.1 8.1 | 50 50 | |
| 766P | IIC | 12 12 | 75 75 | 157 157 | | √ | | Strain-gauge bridges | | 93 93 | 9.8 9.8 | 11.3 11.3 | 100 100 | |
| 787SP | IIC | 28 28 | 234 diode | 119 - | √ | | | Transmitters, controller outputs switches | | 258 0.9V+1.6 Ω | 24.5 24.5 | 26.5 26.5 | 80 80 | |

* Diagram shows positive version. Diodes reversed on negative version.

Patents for MTL707P: UK Patent Nos. 2210521, 2210522; USA Patent No. 4860151

Patents for MTL787SP: UK Patent No. 2210522; USA Patent No. 4860151

Overvolt-protected barrier - MTL707P+

The MTL707P+ (a derivative of the MTL707+) is a two-channel shunt-diode safety barrier similar to the MTL787SP+, but is designed for use with group IIB gases and features built-in electronic overvolt protection allowing use with unregulated power supplies up to 35V dc. It is intended primarily as a low cost solution for driving IIB certified 2-wire 4/20mA transmitters, but can also be used with controller outputs with current monitoring, solenoid valves and switches. To protect the fuse and enable the loop to continue working, the supply current is limited automatically at 50mA should the output be short-circuited or excess voltage applied.

ADDITIONAL SPECIFICATION

Supply voltage - channel 1 (V_s)

10 to 35V dc positive with respect to earth

Output current - channel 1 (I_{out})

Up to 35mA available

Maximum voltage drop (at 20°C, current not limited)

$I_{out} \times 200\Omega + 0.2V$, terminals 1 to 3

$I_{out} \times 18\Omega + 1.3V$, terminals 4 to 2

Supply current

$I_{out} + 2mA$ max, $V_s < 25V$

Limited at 50mA, $V_s > 28V$ or low load resistance

EMC compliance

EN 50 081-2/EN 50 082-2, generic emission/immunity standards. These refer to appropriate IEC/CISPR standards.

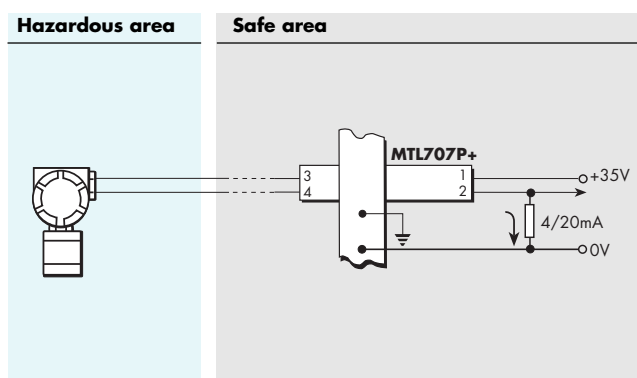

HIGHER-POWER BARRIERS – FOR SENSORS

INPUTS

Strain-gauge bridges

Weighing by load-cell is an application where the lower voltage drop of the MTL766Pac, compared to the MTL766ac, is a great advantage. In such applications, the MTL766Pac supplies power to the bridge while an MTL761Pac interfaces with the sensing and pick-off circuits. Using the two barriers in combination (see Fig. 1), the minimum voltages available in 350Ω bridge systems with a ±10V supply are as follows:-

- 1 bridge: 13.0V
- 2 bridges: 9.7V
- 3 bridges: 7.7V
- 4 bridges: 6.4V

Fire and gas detection

Designed primarily for fire and gas detection systems, the lower maximum end-to-end resistance of the MTL722P+ (121Ω) compared to the MTL722+ (185Ω) can be an advantage (see Fig. 2). In addition, it may prove useful in other 18V dc systems.

Switches, data-loggers, logic systems

The MTL710P+ can be used for supplying power to low-voltage equipment in hazardous areas, such as data-loggers, switches and logic systems. Its low maximum end-to-end resistance of 42Ω, compared to 85Ω for the MTL710+, means it can typically supply more than 65mA current at 5V from an 8V supply (see Fig. 5). It also has the advantage of a higher working voltage (8V compared to 6V for the MTL710+).

The MTL715P+ functions similarly for 12V dc systems and can also be applied to multiple-switch and logic circuits where the additional power proves useful, Fig. 6.

ANALOGUE INPUTS, HIGH-LEVEL

2-wire 4/20mA transmitters

If the supply can be closely regulated, and the transmitter is compatible with the higher power levels available from this barrier in IIC gas groups, the 2-channel MTL787SP+ is recommended. With a 26V supply it provides 14.6V at 20mA for a transmitter and lines as well as the usual 5V for the load, beating the MTL787S+ by 1.7V, Fig. 3.

If the supply is poorly regulated, the 2-channel MTL707P+ provides a low cost solution for IIB applications, where its low end-to-end resistance makes 13V available for the transmitter and field cabling plus 5V for the load when powered from 24V dc, and its overvolt protection allows supply variations up to 35V dc, Fig. 4.

Note: voltage figures shown on busbar are safety description values.

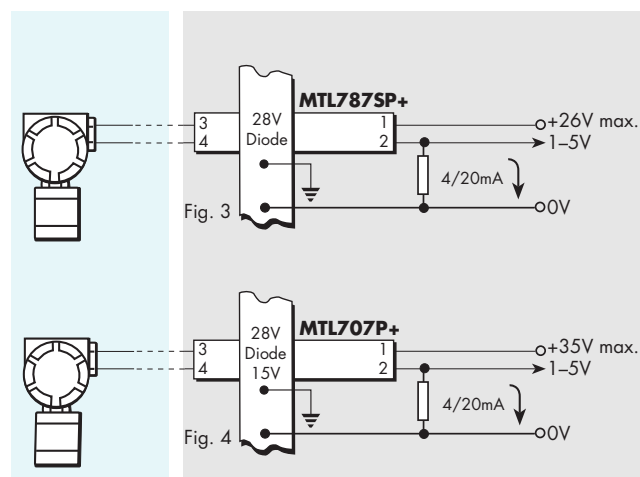
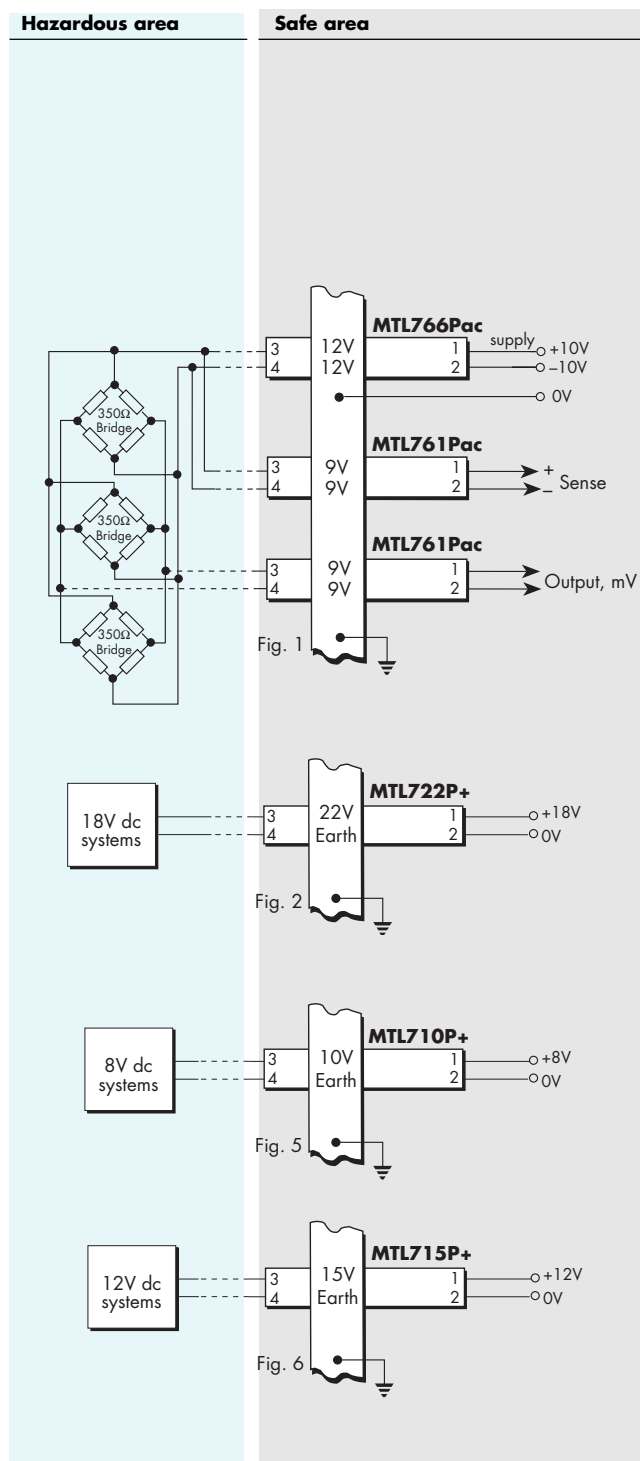

HIGHER-POWER BARRIERS – FOR CONTROL ELEMENTS

ANALOGUE OUTPUTS

Controller outputs – 4 to 20mA

For controller outputs where the output current of the controller flows directly to its '0V' rail, and the rail can be earthed at the busbar, or the output circuit is fully floating, the 1-channel MTL728P+ provides the best solution as the maximum voltage drop introduced by the barrier is only 5.1V at 20mA (compared to 6.8V for the MTL728+), Fig. 7.

For IIB applications, the MTL728P+ can be replaced with the similarly designed 1-channel MTL729P+.

If the output from the controller is separated from the '0V' rail by the control transistor, or the controller contains a resistor for high integrity current monitoring, the 2-channel MTL787SP+ should be used, Fig. 8 and 9. The barrier return channel can handle up to 24.5V, allowing the control signal to be turned off completely. The maximum voltage drop introduced by the barrier is only 6.4V at 20mA (compared to 8.1V for the MTL787S+).

For IIB applications where a 2-channel barrier is needed (see above), the MTL707P+ can be used as, although the overvolt protection provided by this barrier is not necessary, the diode return channel and low voltage drop makes this an ideal replacement for the MTL787S+ for IIB gas groups, Fig. 10.

DIGITAL (ON/OFF) OUTPUTS

Solenoid valves

For IIC applications, the lower end-to-end resistance of the MTL728P+ can make a big difference to the overall loop design when driving higher-power solenoid valves, provided the power supply is well regulated, Fig. 11.

Similarly the MTL729P+ is ideal for powering high-power heavy-duty solenoid valves, in IIB gas group applications, providing a maximum usable output power of 0.78W at 24V, Fig. 12.

If the control switch is on earth, then a 2-channel barrier has to be used, Fig. 13, but be aware that an earth fault on the return line will energise the solenoid, whereas one on the live line does the opposite. If the supply is poorly regulated use the MTL707P+. If it is well regulated use the MTL787SP+. Alternatively, for operational safety, use an MTL5000, 4000, 3000 or 2000 Series isolating interface unit.

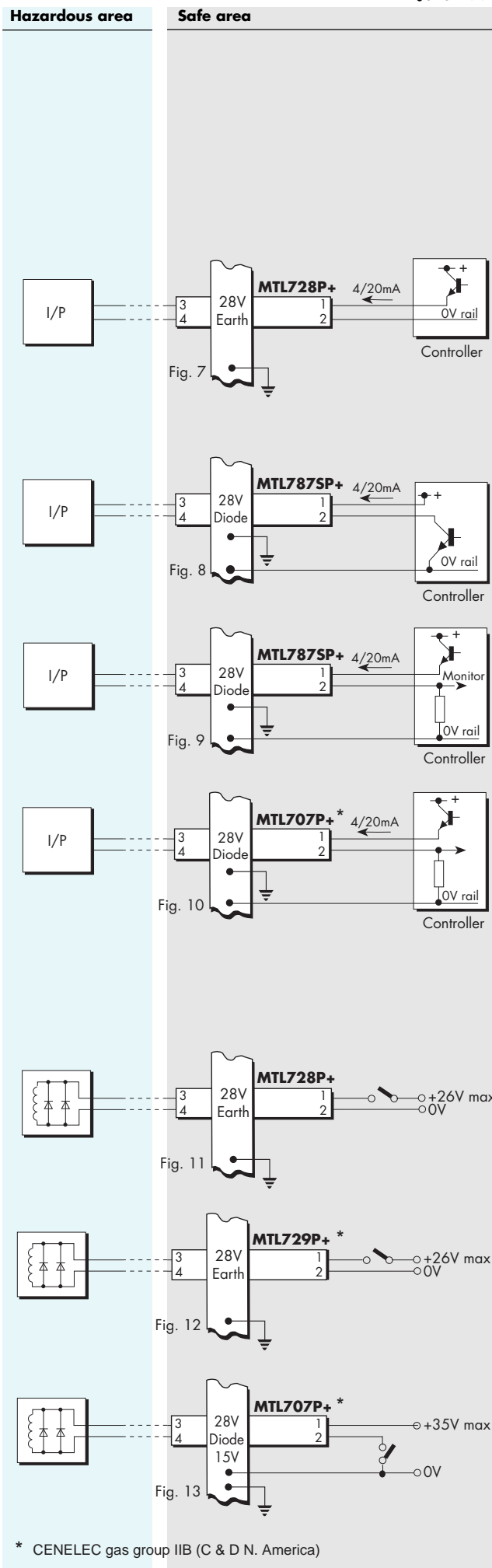

* CENELEC gas group IIB (C & D N. America)

MAXIMUM CABLE PARAMETERS

| Barrier model number MTL | Gas group | Number of single channels interconnected within hazardous area | Earth return used? ¹ | Maximum permissible cable parameters | | | | | Matched power W (BASEEFA) ³ |
|-----------------------------|-----------|--|---------------------------------|--------------------------------------|---------------|--------------------------------|---------------------------|---------------|--|
| | | | | BASEEFA (group IIB) ² | | | FM (group C) | | |
| | | | | Capacitance μF | Inductance mH | L/R ratio $\mu\text{H}/\Omega$ | Capacitance μF | Inductance mH | |
| 707P | IIB | 2 | Yes | 0.39 | 5 | 121 | 0.45 | 6.21 | 1.19 |
| 729P | IIB | 1 | Yes | 0.39 | 5 | 121 | 0.49 | 6.25 | 1.19 |

| Barrier model number MTL | Gas group | Number of single channels interconnected within hazardous area | Earth return used? ¹ | Maximum permissible cable parameters | | | | | Matched power W (BASEEFA) ³ |
|-----------------------------|-----------|--|---------------------------------|--------------------------------------|---------------|--------------------------------|---------------------------|---------------|--|
| | | | | BASEEFA (group IIC) ² | | | FM (groups A & B) | | |
| | | | | Capacitance μF | Inductance mH | L/R ratio $\mu\text{H}/\Omega$ | Capacitance μF | Inductance mH | |
| 710P | IIC | 1 | Yes | 3.0 | 0.395 | 47 | 4.89 | 0.22 | 0.75 |
| 715P | IIC | 1 | Yes | 0.75 | 0.32 | 36 | 1.04 | 0.23 | 1.09 |
| 722P | IIC | 1 | Yes | 0.26 | 0.27 | 29 | 0.33 | 0.53 | 1.17 |
| 728P | IIC | 1 | Yes | 0.13 | 2.47 | 42 | 0.16 | 2.86 | 0.83 |
| 761Pac | IIC | 2 | Yes | 0.42 | 13 | 214 | 0.43 | 14.4 | 0.11 |
| 766Pac | IIC | 2 | Yes | 0.2 | 0.34 | 30 | 0.22 | 0.20 | 0.94 |
| 787SP | IIC | 2 | Yes | 0.13 | 2.47 | 42 | 0.13 | 2.70 | 0.83 |

PERMITTED COMBINATIONS

| System combination | BASEEFA system Cert. No. | Earth return used? ¹ | BASEEFA ² Maximum permissible cable parameters for group IIC (hydrogen) | | | Matched power W ³ |
|--|--------------------------|---------------------------------|---|---------------|--------------------------------|------------------------------|
| | | | Capacitance μF | Inductance mH | L/R ratio $\mu\text{H}/\Omega$ | |
| 2 x 766Pac channels 4 x 761Pac channels | Ex92C2424 | Yes | 0.18 | 0.17 | 18.4 | 1.17 |
| 1 x 715P 4 x 764ac | Ex92C2425 | Yes | 0.135 | 0.23 | 39.3 | 0.91 |

The table gives the maximum permitted cable parameters (including cable and load) for hazardous-area circuits in group IIC gases. However, the table is by no means exhaustive and for full details of other safe combinations, consult either BASEEFA certificate Ex92C2374 or Ex92C2376 or MTL. In practice cable parameters rarely present a problem, as all cables normally used for instrument interconnection have L/R ratios below $25\mu\text{H}/\Omega$ and capacitances below 200pF per metre.

Note 1 If values are not quoted when an earth return is not used, those for an earth return ('Yes' in the table) can be used.

Note 2 For most practical purposes, the values of the parameters for Groups IIB and IIA are respectively three and eight times the values for Group IIC. Values for IIA are 2.6 times those for IIB.

Note 3 The maximum power that could be drawn from the barrier combination under fault conditions. Used for assessing the temperature classification of 'simple' hazardous-area apparatus.

For FM permitted combinations, refer to MTL document SCI-88.

APPROVALS

| Country (Authority) | Standard | Certificate/File No. | | Approved for |
|--|------------------------------------|---------------------------|---|---|
| | | IIB barriers (Gps C-G) | IIC barriers (Gps A-G) | |
| Australia (SA) | AS2380.7-1987 | Ex2065 | Ex2065x | (Ex ia) IIC |
| Canada (CSA) | C22.2, No.157 | LR36637-58 | LR36637-58 LR36637-66* | Class I, II, III, Div.1 Gps A-G |
| China (NEPSI) | GB3836.1-83 GB3836.4-83 | GYJ96298 | GYJ96298 | (ia) IIC T6 (ia) IIB T6 |
| Hungary (BKI) | MSZEN 50 014 & 020 | | 87B2-018 | [EEx ia] IIC |
| UK (BASEEFA to CENELEC standards) | BS 5501:Pts 1&7 EN 50 014 & 020 | Ex92C2375 | Ex92C2373 | [EEx ia] IIC [EEx ia] IIB |
| UK (BASEEFA to CENELEC standards) | BS 5501:Pt 9 EN 50 039 | Ex92C2376 | Ex92C2374 | EEx ia IIC EEx ia IIB |
| UK (BASEEFA (to CENELEC standards), held by MTL India | BS 5501:Pts 1&7 EN 50 014 & 020 | Ex94C2377 | Ex94C2378 | [EEx ia] IIC |
| USA (FM) | 3610 Entity | J.I.0W2A5.AX | J.I.0W2A5.AX J.I.5W0A3. AX (MTL787SP) | Class I, II, III, Div.1 Class I, Div. 2 Gps A-D non-incendive |

*Certification/File No. for MTL787SP only

GENERAL SPECIFICATION AND DIMENSIONS

See MTL700 Series page2-7.

MOUNTING ACCESSORIES, MOUNTING KITS AND ENCLOSURES

See MTL700 and MTL700P enclosures, MTL700 and 700P accessories.

HOW TO ORDER

See MTL700 Series ordering information.