

Signal conversion
into the safe area

MTL5500 SERIES

isolating IS interface units



- ◆ Straight forward 'clip-on' DIN-rail or surface mounting
- ◆ Current and voltage outputs
- ◆ Full input/output and power supply isolation
- ◆ No high integrity earth required

MTL MODEL No.	DESCRIPTION
MTL5521-11-24 MTL5521-11-115 MTL5521-11-230	Frequency - to - Current converter 24Vdc Frequency - to - Current converter 115Vac Frequency - to - Current converter 230Vac
MTL5531-111LI MTL5531-111LI MTL5531-113LI MTL5531-115LI MTL5531-111LU MTL5531-112LU MTL5531-115LU MTL5531-119LU	0-20mA/0-10V in, 4-20mA out 4-20mA/2-10V in, 4-20mA out 0-10mA/0-5V in, 4-20mA out 2-20mA/1-5V in, 4-20mA out 0-20mA/0-10V in, 0-10V out 4-20mA/2-10V in, 0-10V out 0-10mA/0-5V in, 0-10V out 2-10mA or 1-5V in, 0-10V out
MTL5536-11LI MTL5536-11LU	Potentiometer In, 0-20mA out Potentiometer In, 0-10V out

APPROVALS

	CENELEC	FM	CSA
MTL5521	PTB01 ATEX 2060	J.I.3007440	MC157759
MTL5531	PTB01 ATEX 2061	J.I.3007440	MC157759
MTL5536	TÜV01 ATEX 1700	J.I.3007440	MC157759

CABLE PARAMETERS

	ATEX CERTIFICATION				FM		
	Group	μF	mH	$\mu\text{H}/\Omega$	Group	μF	mH
MTL5521	IIC	1	40	-	A+B	1.46	157
	IIB	6.2	150	-	C	4.28	551
					D	11.7	1000
MTL5531	IIC	13.5	1000	-	A+B	13.0	1000
					C	39.2	1000
					D	104	1000
MTL5536	IIC	0.76	20	-	A+B	1.02	29.4
	IIB	4.9	100	-	C	3.08	106
					D	8.21	251

MTL5521 FREQUENCY TO CURRENT CONVERTER AND TRIP AMPLIFIER



The MTL5521 converts a frequency or rotational speed signal from a proximity detector located in the hazardous area into a 0/4–20mA current signal suitable for driving safe area loads. A display located on the top indicates the frequency.

The analogue output provides either a 0–20mA or 4–20mA signal that is proportional to the rotational speed or frequency of the input. A relay output is provided, with two configurable set points, allowing monitoring of the input frequency. When the input frequency is within this window the relay is energised and a yellow LED is illuminated. A start-up delay is triggered by a NO contact allowing the system to start up without creating false alarms.

Configuration settings are made by two push button switches located on the front of the unit allowing the following parameters to be displayed and configured:

- Output current either 0–20mA or 4–20mA
- 0/4mA and 20mA frequency values
- Line fault detection: Off, wire-break and/or short circuit
- Upper and lower threshold values of the set point relay (including hysteresis)
- Start uptime delay 0 to 1000s
- Filter time constant
- Scaling factors

A line fault detect facility detects open and/or short circuits in the field. When a fault is detected the relay de-energises and the yellow LED changes to red.

SPECIFICATION

Number of channels

One, with a configurable alarm

Location of delay switch

Zone 0, IIC, T6 hazardous area

Div. 1, Group A hazardous location

Location of proximity detector

Zone 0, IIC, T4–6 hazardous area if suitably certified

Div. 1, Group A hazardous location

Hazardous-area input (Rotation sensor)

Frequency input	0 to 10kHz
Pulse width	20µs
Start-up delay	0 to 1000s (adjustable)
Input circuits	Input conforms to NAMUR/DIN 19234

Voltage applied to sensor

8.2V from 1kΩ

Input characteristics

Switching threshold	1.55mA
Open-circuit threshold	<0.1mA
Short-circuit threshold	>6mA

Safe-area output

Signal range	0/4 to 20mA
Safe-area load resistance	0 to 500Ω
Filter time constant	0 to 60s in 80ms increments

Relay type

Single-pole changeover relay

Relay characteristics

Switching voltage	<250V ac/120V dc
Switching current	<2A
Switching capacity	<500VA/60W

LED indicators

Green	Power
Yellow K1	Set point relay status
Yellow (Red)	Pulse indication (fault)

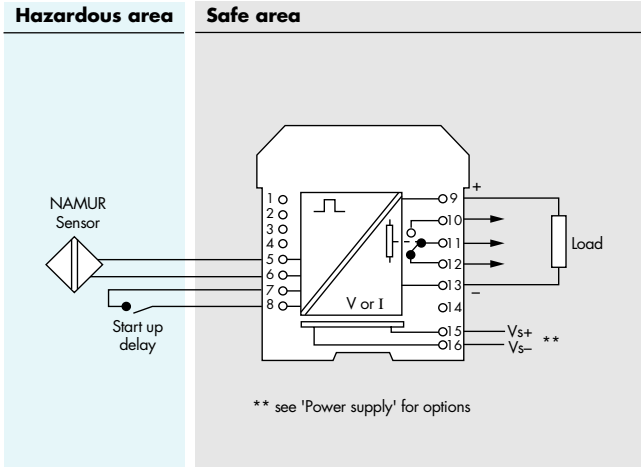

Terminal	Function
5	Namur Sensor +ve
6	Namur Sensor -ve
7	Start up delay +ve
8	Start up delay -ve
9	0/4–20mA output +ve
10	Speed Monitor
11	Speed Monitor
12	Speed Monitor
13	0/4–20mA output -ve
15	Supply +ve
16	Supply -ve

Power supply

230V ac nominal, 184–264V ac, 48–62Hz (MTL5521-11-230)

115V ac nominal, 98–126V ac, 48–62Hz (MTL5521-11-115)

24V dc nominal, 19–29V dc, <10% ripple (MTL5521-11-24)

Power consumption

<5VA/5W

Isolation

250V rms between input, output and power supply terminals, tested at 2.5kV rms between safe and hazardous terminals

Terminals

Each terminal will accommodate 2x2.5mm² conductors

Mounting

On 35mm (top hat) rail

Location of units

Safe area

Ambient temperature limits

Operating temperature –20°C to +60°C

Dimensions

Height (above rail)	105mm
Width	89mm
Rail length required	36mm

Safety description

13V, 30mA (terminals 5–8)

U_m = 250V ac

DIMENSIONS (mm)

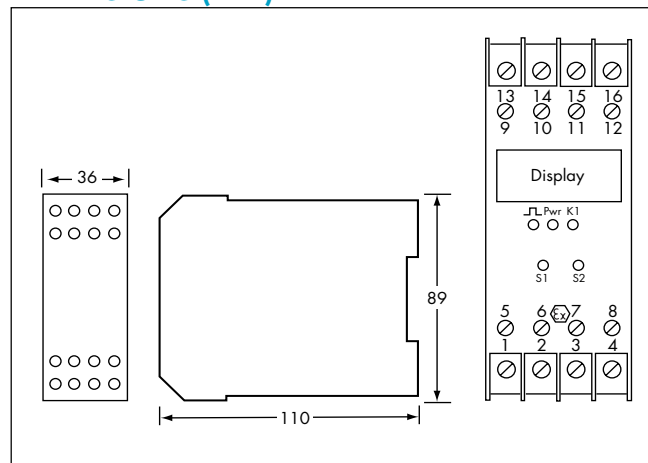

MTL5531 VOLTAGE/ CURRENT CONVERTER



The MTL5531 takes an analogue signal from the hazardous area, either a voltage or current source, then isolates and repeats the signal in the safe area as either a voltage or current signal.

The MTL5531-xxxLI provides a 0/4–20mA output for a range of current or voltage input signals. The MTL5531-xxxLU provides a 0/2–10V output for a range of current or voltage input signals.

SPECIFICATION

Number of channels

One

Location of voltage/current signal

Zone 0, IIC, T4 hazardous area if suitably certified
Div. 1, Group A hazardous location

Hazardous-area input

Current input

Input resistance 100Ω
Operating characteristics 0/4 to 20mA (40mA max.)

Voltage input

Input resistance 50kΩ
Operating characteristics 0/2 to 10V (20V max.)

Safe-area output

Current output

Load resistance <500Ω

Voltage output

Load resistance >500Ω

Output characteristics

Linearity tolerance <0.3% of full scale
Effect of load variation <0.05% of full scale
Effect of supply variation <0.1% of full scale
Ambient temperature <0.02%/C of full scale
Pulse rise time 300ms (10% to 90%)
Release time 300ms (90% to 10%)

LED indicators

Green Power

Power supply (terminals 7 & 8)

24V dc nominal, 19–29V dc, <10% ripple, $U_m = 30V$ dc

Current consumption

Approx. 50mA at 24V dc

Isolation

250V rms between input, output and power supply terminals, tested at 2.5kV rms between safe and hazardous terminals

Terminals

Each terminal will accommodate 2x2.5mm² conductors

Mounting

On 35mm (top hat) rail

Location of units

Safe area

Ambient temperature limits

Operating temperature –20°C to +60°C

Dimensions

Height (above rail) 65mm
Width 89mm
Rail length required 18mm

Safety description

7.2V, 1mA (terminals 1, 2 & 3, 4)
 $U_m = 250V$ ac (terminals 5 & 6)

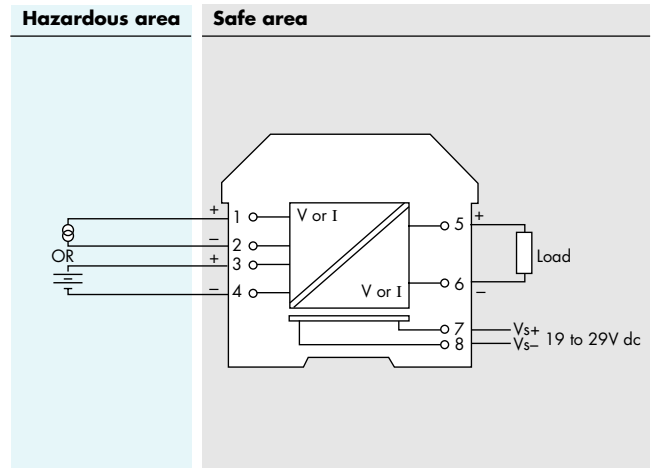

Terminal	Function
1	0/4–20mA +ve
2	0/4–20mA –ve OR
3	0/2–10V +ve
4	0/2–10V –ve
5	LI: 0/4–20mA out +ve LU: 0/2–10V out +ve
6	LI: 0/4–20mA out –ve LU: 0/2–10V –ve
7	Supply +ve
8	Supply –ve

DIMENSIONS (mm)

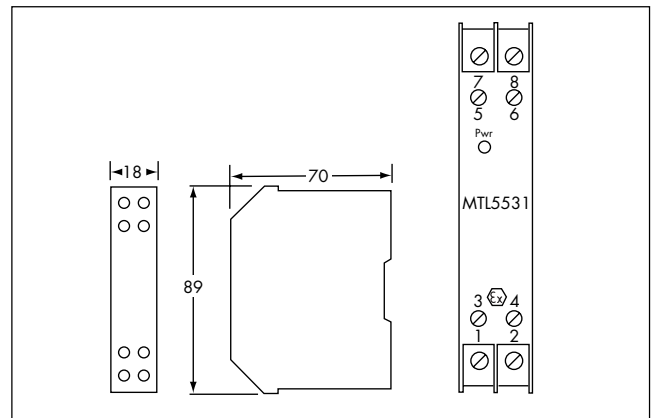

ORDERING OPTIONS

Current output

Input range	0–20mA output	4–20mA output
0–20mA/0–10V	MTL5531-111LI	MTL5531-111LI
4–20mA/2–10V		MTL5531-111LI
0–10mA/0–5V	MTL5531-115LI	MTL5531-113LI
2–10mA/1–5V		MTL5531-115LI

Voltage output

Input range	0–10V output	2–10V output
0–20mA/0–10V	MTL5531-111LU	
4–20mA/2–10V	MTL5531-112LU	MTL5531-111LU
0–10mA/0–5V	MTL5531-115LU	
2–10mA/1–5V	MTL5531-119LU	MTL5531-115LU

MTL5536 POTENTIOMETER CONVERTER



The MTL5536 converts a low level dc signal from a 3- or 5- wire potentiometer in a hazardous area into a 0–20mA current or 0–10V output for driving a safe area load. Potentiometer inputs can range from 800Ω to 20kΩ. The MTL5536 is available with a current output (MTL5536-11LI) or with a voltage output (5536-11LU).

SPECIFICATION

Number of channels

One

Location of potentiometer

Zone 0, IIC, T4 hazardous area if suitably certified
Div. 1, Group A hazardous location

Hazardous-area input

Potentiometer input 3- or 5-wire input
Potentiometer resistance 800Ω to 20kΩ
Line resistance <50Ω with a 800Ω potentiometer
Voltage at potentiometer 5V

Safe-area output

Current output option MTL5536-11LI
Load <500Ω
Output current 0–20mA
Voltage output option MTL5536-11LU
Load >500Ω
Output voltage 0–10V

Transfer characteristics

Linearity error of set point <0.1% of final value
Measuring tolerance <0.2% (typ 0.1%)
Long term error 0.1%/year
Temperature coefficient <0.02%/K of final value
Pulse rise time <100ms (10–90%)
Release time <100ms (90–10%)

LED indicators

Green Power

Power supply

24V dc nominal, 19–29V dc, <10% ripple

Current consumption

Approx. 50mA at 24V dc

Isolation

250V rms between input, output and power supply terminals, tested at 2.5kV rms between safe and hazardous terminals

Terminals

Removable terminals accommodating a 2.5mm² conductor

Mounting

On 35mm (top hat) rail

Location of units

Safe area

Ambient temperature limits

Operating temperature –20°C to +60°C

Dimensions

Height (above rail) 105mm
Width 104mm
Rail length required 18mm

Safety description

13.8V, 35mA, 121mW (terminals 1–6)
U_m = 250V ac

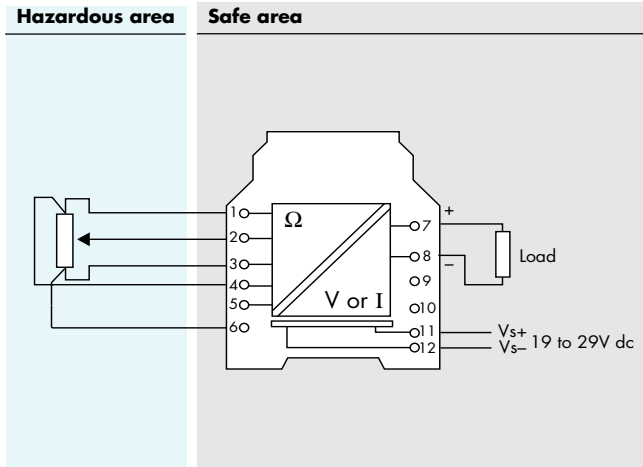

Terminal	Function
1	3 wire pot +ve
2	Pot wiper
3	3 wire pot –ve
4	5 wire pot +ve
6	5 wire pot –ve
7	LI: 0–20mA out +ve LU: 0–10V out +ve
8	LI: 0–20mA out –ve LU: 0–10V out –ve
11	Supply +ve
12	Supply –ve

DIMENSIONS (mm)

